



Brain Slice Keeper

BSK12

Pre-Incubation of Slice Preparations

The BSK12 Brain Slice Keeper has been designed to pre-incubate a large number of brain slices prior to transfer into recording chambers or for the incubation of preparations in experimental test media. This keeper consists of twelve closely fitting acrylic 'C' rings that fit into their own through-hole, located in a circular manifold. Removable netting is wedged between the 'C' ring and it's hole.

FEATURES

- * Slices maintained for many hours in incubating media
- * Twelve separate rings allow separation of different types of preparations
- * Slices supported on a quick change nylon net
- * Modular design simple to set up and maintain

In operation, the twelve rings located on a manifold with netting are totally immersed in an ACSF-filled purpose designed holding vessel into which a 95% O₂, 5% CO₂ gas mixture is supplied through a ceramic bubbler. The ceramic bubbler is located in a central tube chamber connected to the upper manifold. The bubbles rising from the base saturate the ACSF and provide constant circulation of medium to the slices which rest on the nylon nets. Bubbles are restricted to rising in the central chamber and are prevented from being trapped under the slices, thereby ensuring a continuous circulation of medium. Slices remain viable for many hours in these conditions. The BSK12 together with the holding vessel can be easily placed into a water bath for regulating the incubating temperature as desired. A lid with a conical profile ensures that condensation drops do not fall directly above the slices. When in place, the fluid level is maintained at least 3mm above the 'C' rings. This ensures circulation of fluid over the top and downwards towards the slices. The typical fluid volume with BSK12 is 500ml but can be reduced by adding large glass spheres into the base.



BSK12 Brain slice keeper with rings and net in place and with lid in place (inset). A needle valve is used to control the flow of oxygen mixture to the ceramic bubbler.



Brain Slice Keeper

BSK12

Pre-Incubation of Slice Preparations

Brain slice keeper schematic

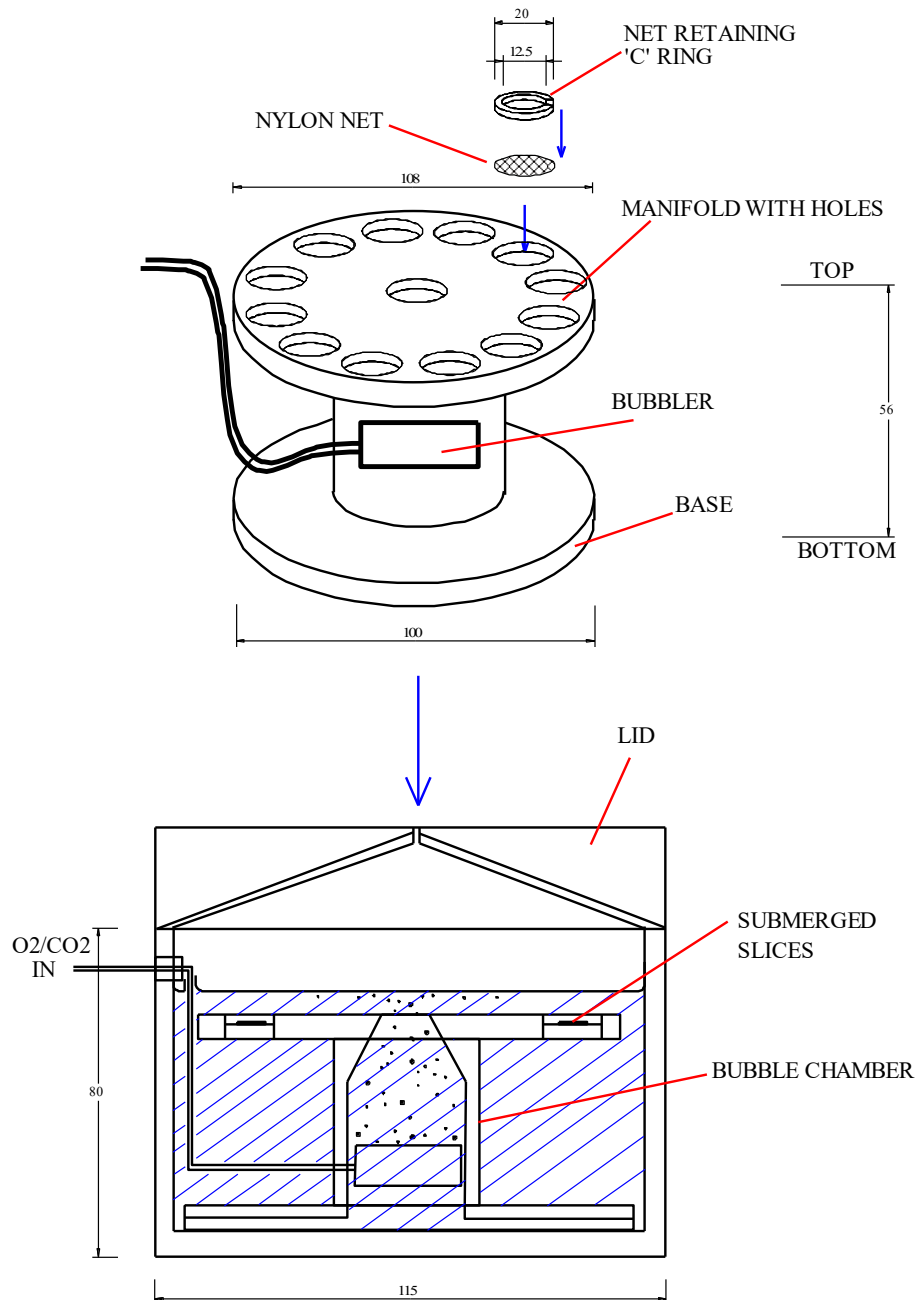

Schematic arrangement of BSK12 and location in purpose designed trough with conical profiled lid. Approximate dimensions are in mm.