



**Scientific  
Systems  
Design Inc**

1365 #14 Mid-way Blvd  
Mississauga  
Ontario  
L5T 2J5  
**CANADA**

Phone: 1 905 608 9307  
ssd@scisys.info  
www.scisys.info

---

*Innovative Engineering for Science*

---

**MICROSCOPE STAGE SLICE  
CHAMBER**

**MS2**

## MICROSCOPE STAGE SLICE CHAMBER

### CAUTION !

**YOUR MICROSCOPE STAGE SLICE CHAMBER IS A PRECISION ENGINEERED TOOL FOR SCIENTIFIC RESEARCH. PLEASE TAKE A FEW MINUTES TO FAMILIARISE YOURSELF WITH THE KEEPER AND READ THROUGH THIS SHORT MANUAL BEFORE ATTEMPTING TO USE IT.**

**DO NOT USE ALCOHOL OR SIMILAR SOLVENTS IN ANY CONCENTRATION ON ANY PART OF THE KEEPER SINCE AS WITH MOST ACRYLICS, IT MAY FRAGMENT OR DEVELOP HAIR-LINE CRACKS. DO NOT AUTOCLAVE AS HEAT MAY CAUSE STRESS CRACKS TO DEVELOP.**

### OPERATION

Designed for submerged preparations, with imilar construction to MS1 chamber offering clearance for rotary and swing type microscope objective turrets. Central area has glass bottom with 2mm gap above which is a piece of replaceable netting trapped by a 'C' ring (similar to BSC3 construction). The netting is trapped under the 'C' ring tightly by stretching after it is inserted and cutting off the excess around the rim. The position of the netting above the glass base at the bottom with the slice place on top provides aCSF perfusion on both sides of the slice.

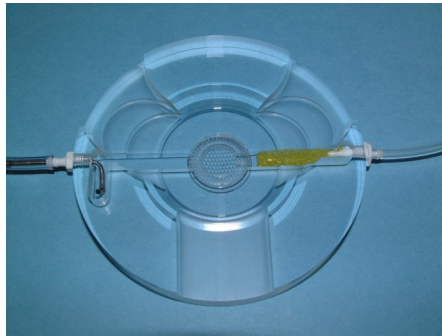

### FEATURES

- \* 1.5 ml capacity flow through upright microscope stage chamber
- \* Unique profiled contour for rotary and swing type turrets for par-focal viewing
- \* Glass cover slip base
- \* Slice exposed to aCSF from both sides
- \* Temperature control unit available

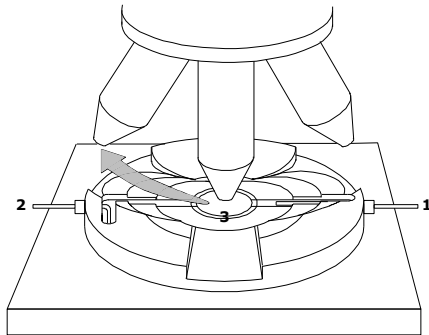

Perfusion solution enters from one side [1] and is passed through a buffer material to smooth out flow and exits through a well [2] in which a movable 'L' tube attached to a pump / suction line adjusts the fluid level. Solutions can be pre-warmed before entering the chamber with our Mini Heating Module **MH02**. Incoming fluid floods area contained within 'C' ring above netting where slice rests. Solution path is above and below slices. The exit of solution is under the closed side of the 'C' ring so that fluid is made to flow over the slice and down to the exit channel.

### SPECIFICATIONS

Size: 100mm diameter X 12mm

Material: Clear acrylic

Cover slip base: 22mm X 150um (No. 2)

Inlet tube: passes through buffer material

Exit tube: Special 'L' shaped for height adjustment

Dead space: Min. capacity of pool formed above cover slip and channels leading to inlet and exit ports is 1.5ml.

### MAINTENANCE

Alcohol should never be used on the slice chamber for cleaning purposes even at low concentrations because it de-hydrates and produces hair-line cracks in acrylic plastics. Do not autoclave the MS2 as the heat cycle can lead to stress cracking of the acrylic.

A laboratory detergent which completely rinses out should be used. The acrylic component can be cleaned with special laboratory detergents such as \*Micro-90™ which completely rinses out. Heavy deposits of salts should be washed out with distilled water overnight and carbonate salts treated with mild acids such as citric acid. The most common contaminant is fungal growth, this can be avoided by washing out with distilled water and drying out completely at the end of each day. Hydrogen peroxide solution is also an effective cleaning agent.

### FREQUENTLY ASKED QUESTIONS

**My perfusion solution forms large globules around the center of the chamber and has difficulty forming a continuous inflow-outflow stream, why does this happen?**  
*This will happen with a new chamber or one that has just been thoroughly cleaned. The polished surfaces of acrylic are hydrophobic, so solutions tend to form globules rather than forming a curved meniscus with the walls and channels of the chamber. To overcome this problem for a new chamber or one that has been thoroughly cleaned, leave a saline (not ACSF) solution to form a pool in the chamber overnight. Rinse as normal before use for the next experiment. We believe that small amounts of salt adhere to the surface thus allowing the meniscus to form. An alternative approach is to cut strips of lens tissue 5mm in width and lay these along the inlet and exit channels to encourage flow across. In some situations it may be necessary to place a piece of lens tissue at the mouth of the exit tube to encourage smooth outflow if the peristaltic pump exhibits too much vibration.*

#### How do you hold slices down?

The most reliable method is to prepare a U-shaped piece of stainless steel wire, which is then partially flattened to form a suitable surface for adhesive. Thin strands of nylon such as those obtained by separating out the individual fibres in a length of string from dental floss are positioned taught across the U-shape. Cyano-acrylate adhesive is then applied to the flattened surface on which the fine nylon threads are held taught. Once completely dry the excess ends of the fibres are cut. This "harp" is then sunk over the submerged slice preparation. We can supply these, please contact us.

#### What is the best method of cleaning the chamber after use?

Rinse with plenty of distilled water and leave dry before the next experiment. **NEVER use a solvent of any kind as acrylics tend to fragment and can be completely destroyed.** A mild acid (citric) should be used to get rid of deposits, and then left in a large volume of distilled water overnight.

#### How do I replace the cover slip if it should break?

Wear safety goggles for this procedure. First place the chamber upside down on a flat, soft surface (cork tile) and GENTLY remove all the broken glass, using a small flat ended spatula in a scraping action to remove the old silicone rubber sealant. DO NOT use any kind of solvent to remove the sealant. Once completely clear, use a syringe loaded with silicone sealant and bead this around the circumference of the indentation. Place a clean no. 2 thickness, 22mm cover slip on the fresh sealant and GENTLY press around the circumference ONLY of the cover slip. It is preferable to use a black sealant as it allows the thickness of the sealant to be controlled: darker areas have too much sealant under the cover slip. Try to ensure the final position of the cover slip is central and also very slightly BELOW the UNDERSIDE surface of the chamber, so that when it rests on the microscope stage, the cover slip does not rub on the stage surface. The indentation for the cover slip is 300um in depth, the cover slip supplied with the chamber is around 150- 200um, giving room for a thin layer of sealant. Remove excess sealant whilst still wet, taking care not to displace the cover slip. Alternatively return the chamber to us and we will replace the cover slip.

#### Where is the best electrical ground point?

This will have to be found by trial and error. In addition to the AgCl type wire electrode you can ground the original stainless steel inlet and outlet tube to help to eliminate any artefacts from the suction line. Quite often it helps to push a grounding wire INTO the wall of silicone rubber tubes that you use for connection to your perfusion solutions, either or both the input and exit lines.

\*Micro-90™ is a trademark of International Products Corporation USA