

How do you hold slices down?

The most reliable method is to prepare a U-shaped piece of stainless steel wire, which is then partially flattened to form a suitable surface for adhesive. Thin strands of nylon such as those obtained by separating out the individual fibres in a length of string from dental floss are positioned taught across the U-shape. Cyano-acrylate adhesive is then applied to the flattened surface on which the fine nylon threads are held taught. Once completely dry the excess ends of the fibres are cut. This "harp" is then sunk over the submerged slice preparation. We are now manufacturing suitable slice holders, for this chamber we recommend SH13, details available on our website.

What is the best method of cleaning the chamber after use?

Rinse with plenty of distilled water and leave dry before the next experiment. **NEVER use a solvent of any kind as acrylics tend to fragment and can be completely destroyed.** A mild acid (citric) should be used to get rid of deposits, and then left in a large volume of distilled water overnight. For deep cleaning use a solution of *Micro-90™ which is a special detergent that will rinse out completely. Please ask for details.

How do I replace the cover slip if it should break?

Wear safety goggles for this procedure. First place the chamber upside down on a flat, soft surface (cork tile) and GENTLY remove all the broken glass, using a small flat ended spatula in a scraping action to remove the old silicone rubber sealant. DO NOT use any kind of solvent to remove the sealant. Once completely clear, use a syringe loaded with silicone sealant and bead this around the circumference of the indentation. Place a clean no. 2 thickness, 22mm cover slip on the fresh sealant and GENTLY press around the circumference ONLY of the cover slip. It is preferable to use a black sealant as it allows the thickness of the sealant to be controlled: darker areas have too much sealant under the cover slip. Try to ensure the final position of the cover slip is central and also very slightly BELOW the UNDERSIDE surface of the chamber, so that when it rests on the microscope stage, the cover slip does not rub on the stage surface. The indentation for the cover slip is 300um in depth, the cover slip supplied with the chamber is around 150- 200um, giving room for a thin layer of sealant. Remove excess sealant whilst still wet, taking care not to displace the cover slip. Alternatively return the chamber to us and we will replace the cover slip.

Where is the best electrical ground point?

This will have to be found by trial and error. In addition to the AgCl type wire electrode you can ground the original stainless steel inlet and outlet tube to help to eliminate any artefacts from the suction line. Quite often it helps to push a grounding wire INTO the wall of silicone rubber tubes that you use for connection to your perfusion solutions, either or both the input and exit lines.



**Scientific
Systems
Design Inc**

50 #5 Steeles Ave East
Milton, Ontario L9T 4W9
CANADA

Phone: 1 905 608 9307
ssd@scisys.info
www.scisys.info

Innovative Engineering for Science

**MICROSCOPE STAGE
SLICE CHAMBER**

MS1

*Micro-90™ is a trademark of International Products Corporation USA

MICROSCOPE STAGE CHAMBER

CAUTION !

YOUR MICROSCOPE STAGE CHAMBER IS A PRECISION ENGINEERED TOOL FOR SCIENTIFIC RESEARCH. PLEASE TAKE A FEW MINUTES TO FAMILIARISE YOURSELF WITH THE KEEPER AND READ THROUGH THIS SHORT MANUAL BEFORE ATTEMPTING TO USE IT.

DO NOT USE ALCOHOL OR SIMILAR SOLVENTS IN ANY CONCENTRATION ON ANY PART OF THE KEEPER SINCE AS WITH MOST ACRYLICS, IT MAY FRAGMENT OR DEVELOP HAIR-LINE CRACKS. DO NOT AUTOCLAVE AS HEAT CYCLING CAN CAUSE STRESS CRACKS IN ACRYLIC.

OPERATION

The MS-1 chamber has been designed for use with fixed-stage upright-type microscopes. The particular feature of this chamber is the profiled contour that allows the microscope objective to sweep across the preparation when changing magnification, without having to adjust the focusing. In this way the specimen and any pre-positioned microelectrodes remain par-focal. This is particularly useful for confocal microscopy where it is the intention to combine electrophysiology and precise localisation of structures. In addition this chamber can be utilised with microscopes that have front to back swing objective turrets. Adaptor plates are available for various microscope stages.

FEATURES

- * 1 ml capacity flow through upright microscope stage chamber
- * Unique profiled contour for rotary and swing type turrets for par-focal viewing
- * Glass cover slip base
- * Easy chamber removal for cleaning
- * Temperature control unit available

Perfusion solution enters from one side [1] via a stainless steel tube and exits through a well [2] in which a movable tube attached to a pump / suction line adjusts the fluid level. Solutions can be pre-warmed before entering the chamber with our Mini Heating Module MH02. The profile slopes in towards the central coverslip base [3] so that the perfusion solution forms a pool around the preparation whilst being refreshed by virtue of the inlet and exit ports.

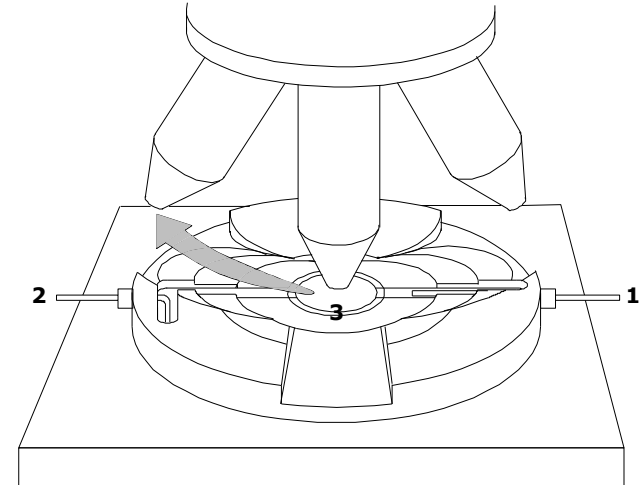
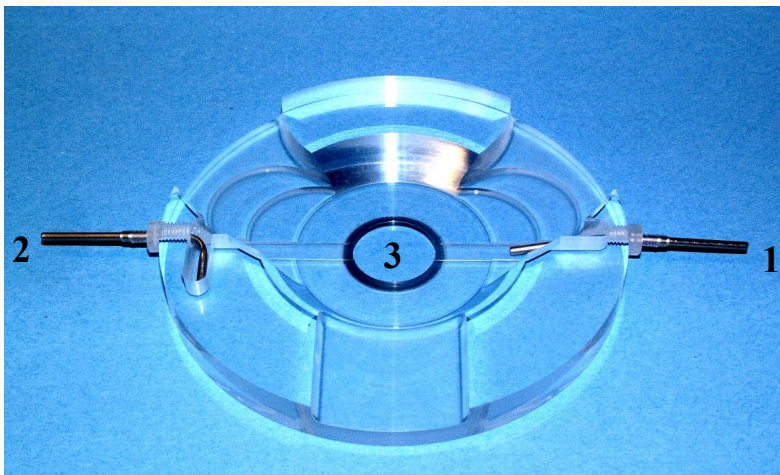

SPECIFICATIONS

Size: 100mm diameter X 12mm (Other sizes available)
Material: Clear acrylic
Cover slip base: 22mm X 150um (No. 2)
Inlet tube: Stainless steel tube, 1.8 mm O.D.
Exit tube: As for inlet tube
Dead space: Min. capacity of pool formed above cover slip and channels leading to inlet and exit ports is 1ml.

FREQUENTLY ASKED QUESTIONS

My perfusion solution forms large globules around the center of the chamber and has difficulty forming a continuous inflow-outflow stream, why does this happen?

This will happen with a new chamber or one that has just been thoroughly cleaned. The polished surfaces of acrylic are hydrophobic, so solutions tend to form globules rather than forming a curved meniscus with the walls and channels of the chamber. To overcome this problem for a new chamber or one that has been thoroughly cleaned, leave a saline (not ACSF) solution to form a pool in the chamber overnight. Rinse as normal before use for the next experiment. We believe that small amounts of salt adhere to the surface thus allowing the meniscus to form. An alternative approach is to cut strips of lens tissue 5mm in width and lay these along the inlet and exit channels to encourage flow across. In some situations it may be necessary to place a piece of lens tissue at the mouth of the exit tube to encourage smooth outflow if the peristaltic pump exhibits too much vibration.